

interface BRACKET
CENTER recording to
drawing Z-003467

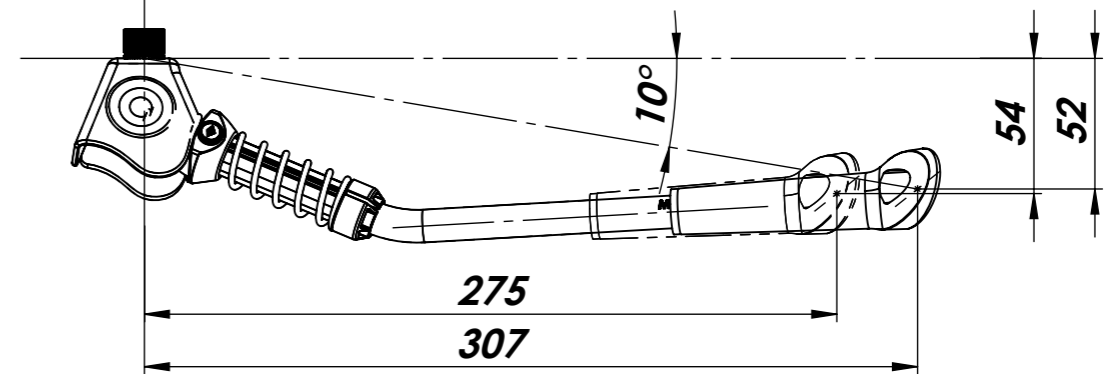

Modification note		Modified by IK	Date 12.05.2025
Edges: -0,5	Project no. EP-1756	Document status Engineering released	
	Project name LEX m	Revision 2D C	Revision 3D rev-03
3rd Angle Projection	Material Semi-finished part	Surface finish Colour black	Art. no. 0630 E
Surfaces ISO 1302 Workpiece edges ISO 13715 General tolerance ISO 2768-mK and ISO 8015	hebie Hebie GmbH & Co. KG Sandhagen 16 D-33617 Bielefeld	tubus tubus carrier systems GmbH Vinkamp 24 D-48157 Münster	Description kickstand LEX
		Additional specification central, monopod, steel, adjust.	
		Drawing no. Z-003618	